



NATIONAL SENIOR CERTIFICATE EXAMINATION
NOVEMBER 2015

MATHEMATICS: PAPER I

Time: 3 hours

150 marks

PLEASE READ THE FOLLOWING INSTRUCTIONS CAREFULLY

1. This question paper consists of 12 pages and an Information Sheet of 2 pages (i – ii). Please check that your paper is complete.
 2. Read the questions carefully.
 3. Answer all the questions.
 4. Number your answers exactly as the questions are numbered.
 5. You may use an approved non-programmable and non-graphical calculator, unless otherwise stated.
 6. Round off your answers to one decimal digit where necessary.
 7. All the necessary working details must be clearly shown.
 8. It is in your own interest to write legibly and to present your work neatly.
-

SECTION A

QUESTION 1

(a) Solve for x :

(1) $(x-3)(x+1) = 5$ (3)

(2) $9^{2x-1} = \frac{3^x}{3}$ (3)

(3) $2\sqrt{2-7x} = \sqrt{-36x}$ (3)

(b) Determine, in terms of k , the co-ordinates of the points of intersection of the graphs of $y = kx + k$ and $y = x^2 + 2kx + k$, where $k \in \mathbb{R}$. (5)

(c) Given: $9x^2 + nx + 49 = 0$

(1) Express the roots of the equation in terms of n . (2)

(2) For what value(s) of n will the roots be equal? (2)

[18]

QUESTION 2

(a) Given: $f(x) = \frac{1}{x+1} + 2$

(1) Write down the equations of the asymptotes of f . (2)

(2) Determine the x and y -intercepts of the graph of f . (3)

(3) Sketch the graph of f . Show all asymptotes and intercepts with axes. (3)

(b) Given: $g(x) = 2 \cdot 3^x - 1$

(1) Determine the intercepts with axes, correct to 2 decimal digits, if necessary. (4)

(2) Sketch the graph of g . Label clearly all asymptotes and intercepts with axes. (3)

[15]

QUESTION 3

Saien purchased an Internet Café for R1 800 000. He paid a deposit of 60% and financed the balance through a banking institution. The bank offered him the loan which had to be repaid at the end of each month at an interest rate of 8% per annum compounded monthly.

The first payment is made one month after the loan is received.

- (a) Show that the monthly instalment to the nearest Rand is R8 736, if the loan repayment period was 10 years. Show all working. (5)
- (b) Based on the monthly instalment of R8 736, calculate the outstanding balance of the loan after 3 years, i.e. immediately after the 36th payment. Round off your answer to the nearest Rand where necessary. Show all working. (5)
- (c) Making reference to your answer to (b), what percentage of the total monthly instalments paid over the 3 year period went towards paying the bank's interest charges? Give your answer to the nearest whole number. Show all working. (4)
- [14]**

QUESTION 4

- (a) Given $f(x) = \frac{7}{x}$, determine $f'(x)$ from first principles. (4)
- (b) Differentiate with respect to x : $\frac{14\pi}{x^{-1}} - 3\sqrt[3]{x^2}$. Leave your answer in positive exponents. (4)
- [8]**

QUESTION 5

- (a) The first term of an arithmetic sequence is 6 and the fifth term is 18.

Calculate the sum to 38 terms of this sequence.

(4)

- (b)



A computer tablet infected with a malware programme (computer-generated virus) has resulted in its flat rectangular screen being affected by $\frac{1}{3}$ of the screen being blocked on the first day. On each successive day it blocks a further $\frac{1}{3}$ of the area it blocked on the previous day.

The malware programme continues to act indefinitely.

Before this infection, the area of the flat screen is 1 000 square units.

- (1) Determine the total area blocked at the end of three days. (3)
- (2) If the malware programme continues to act indefinitely, what fraction of the user's screen will eventually be blocked out? (3)

[10]

QUESTION 6

- (a) The graph of $y = ax^2 + bx + c$ is sketched, where $a, b, c \in \mathbb{R}$.

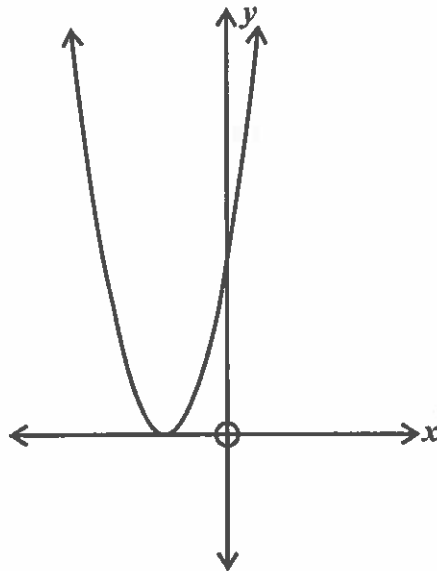

For each of the equations given, choose the statement ((i), (ii), or (iii)) that applies.

- | | | |
|-------|----------------------------|-----|
| (1) | $ax^2 + bx + c = 0$ | (1) |
| (2) | $ax^2 + bx + c = -2$ | (1) |
| (3) | $ax^2 + bx + c = 4$ | (1) |
| (i) | Roots are non-real | |
| (ii) | Roots are real and unequal | |
| (iii) | Roots are real and equal | |

(b) The diagram below shows a picture of a bow and arrow.

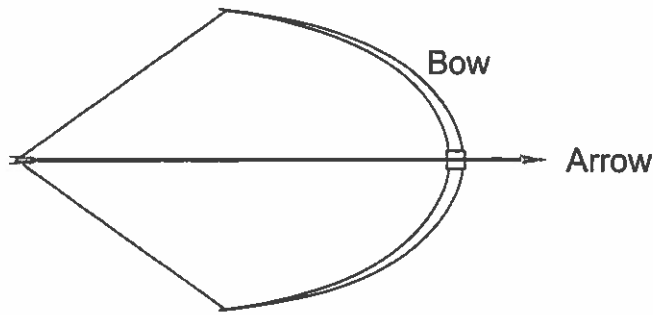

This picture is represented on the set of axes below.

Points $A(3 ; 0)$, $B(7 ; 0)$ and $E(6 ; 6)$ are given. CD is perpendicular to AB .

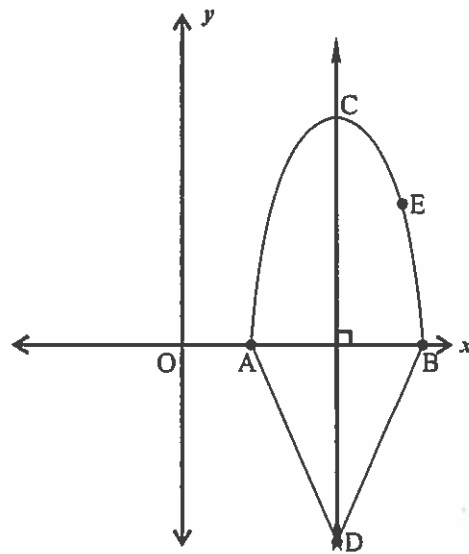

- (1) Determine the equation of the parabola in the form $y = ax^2 + bx + c$. (4)
- (2) Determine the equation of the line AD if the gradient of AD = -2 . (3)
- (3) Hence determine the length of CD. (4)

- (c) The arrow will follow a parabolic path, with maximum at the point of release.

It is given that the equation of its path is $f(x) = -\frac{1}{50}(x^2 - 100)$; $0 \leq x \leq 10$.

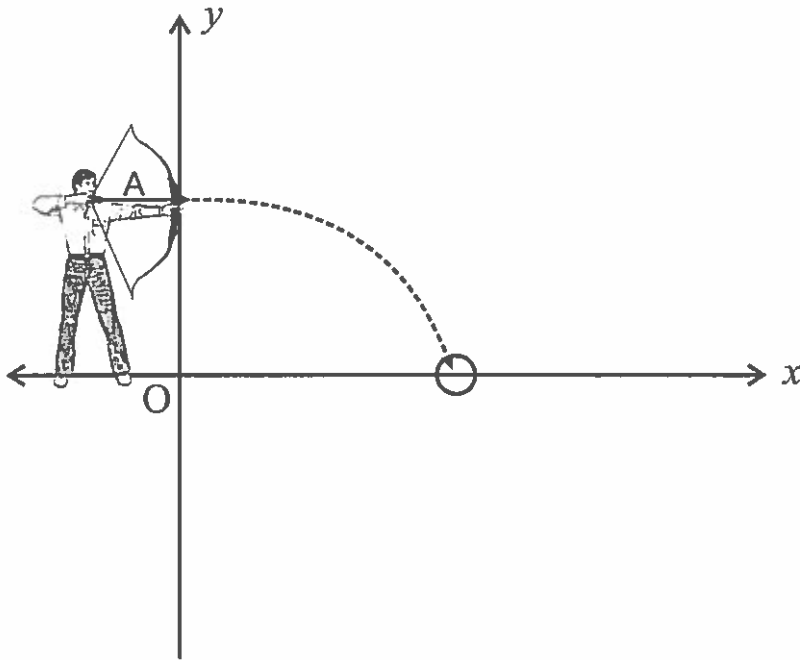

Write down the equation of the inverse function $f^{-1}(x)$, and state its domain. (3)
[17]

82 marks

SECTION B

QUESTION 7

A graph of a cubic function f is drawn on a set of axes.

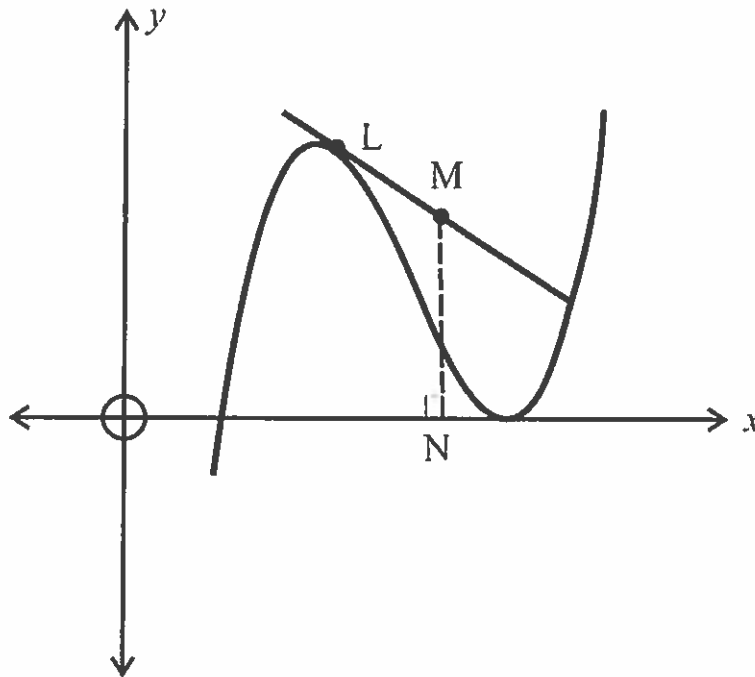

The equation of the curve is given as $f(x) = 3x^3 + bx^2 + cx - 27$, where b and c are constants.

$$f'(1) = 12 \quad \text{and} \quad f''(1) = -24$$

- (a) Show that the equation of the curve is $f(x) = 3x^3 - 21x^2 + 45x - 27$. (7)
- (b) Give the values of x for which the graph is concave down. (3)
- (c) If LM is a tangent to the curve at $L(2; 3)$, determine the length MN in terms of p if N is the point $(p, 0)$ and MN is perpendicular to the x -axis. (5)
- (d) Solve for x , giving the exact solution if $\frac{f'(x)}{f(x)} \leq 0$. (8)

[23]

QUESTION 8

- (a) The following sequence $10 - 3y ; 7 ; 15 ; 8y + 1$ is a quadratic sequence. Determine the value of y . (4)
- (b) The following figure represents a pyramid scheme. Each square represents an investor.

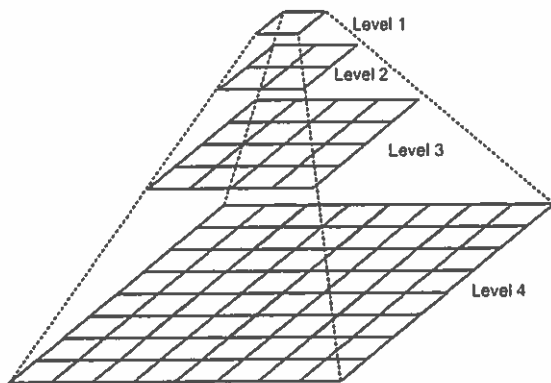

Level	Number of investors
1	1
2	4
3	16
4	64

Assume that this pattern remains consistent and continues.

- (1) If each investor invests R250, determine the level at which the total contributions (that is, from level 1 to that level) add up to R21 845 250. (5)
- (2) Determine between which two consecutive levels the difference in the number of investors is given by 6×2^{17} . (7)

[16]

QUESTION 9

- (a) A box contains 7 cards numbered 1 to 7. Two cards are drawn at random without replacement. Find the probability that the numbers on the two cards drawn out of the box give an odd product.

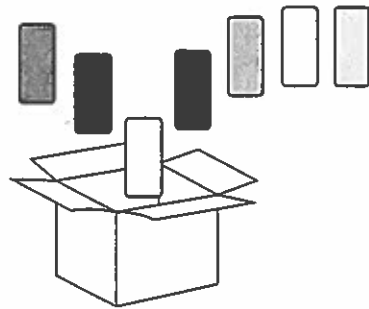

(4)

- (b) For two events A and B, in the sample space S, it is given that $P(A) = 0,55$; $P(B) = 0,6$ and $P(A \text{ and } B) = 0,25$.

(1) Draw a Venn diagram to represent the information. Determine: (3)

(2) $P(A \text{ and } B')$ (2)

(3) $P(A \text{ or } B')$ (1)

- (c) A group of friends decide to plan a trip to Europe with the intention of visiting Rome, Madrid, Florence, Milan, Geneva and Paris. They choose the order of their visits randomly.

(1) Determine the possible number of different orders of their visits. (1)

(2) If Rome, Madrid and Florence are grouped together in that order, determine the number of different orders of their visits. (1)

(3) What is the probability that they will visit Rome, Madrid and Florence one after the other in any order. Give your answer correct to one decimal place. (3)

[15]

QUESTION 10

- (a) The diagram below shows a solid right circular cone that is set centrally within a hemispherical container.

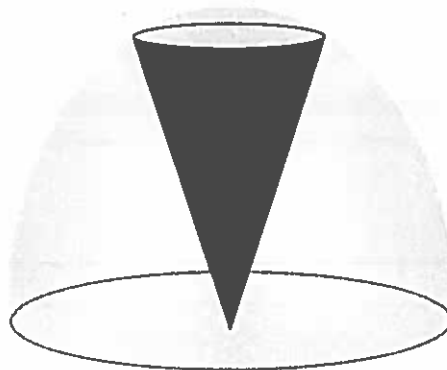

The radius of the hemisphere is $5\sqrt{3}$ cm. Of all possible right circular cones that can fit into the hemisphere, calculate, showing all working, the value of x (height of the cone in cm) for which the cone will have a maximum volume. Let radius of cone be p cm.

Useful formulae:

$$\text{Volume of a Sphere} = \frac{4}{3}\pi r^3$$

$$\text{Volume of a right circular cone} = \frac{1}{3}\pi r^2 H \quad (7)$$

- (b) Busi would like to become an Olympic sprinter.

Her younger sister Khanya helps by racing against her.

When they tried the 100 metre sprint, Busi crossed the winning line when Khanya was still 25 metres short of it.

Busi wanted something more challenging, so it was agreed that Busi would start 25 metres behind the starting line.

They both ran at exactly the same speeds as in the first race.

Where was Busi and Khanya when the winning line was crossed by whoever arrived at it first? Explain your answer.

(7)
[14]

68 marks

Total: 150 marks